



**CommandLIFT™**  
**REMOTE DOOR SYSTEM**  
[www.commandlift.com](http://www.commandlift.com)

## TABLE OF CONTENTS

PAGE NUMBER	DESCRIPTION
2	PRE INSTALLATION CHECKLIST
3	ELECTRICAL REQUIREMENTS
4 - 5	PRE INSTALLATION MAINTENANCE
6	MOUNTING THE DOOR PLATE
7	CHANGING THE CENTER BALANCER BRACKET
8 - 9	JOINING TWO SECTION TRACKS
10 - 12	SECURING THE TRACK TO THE VEHICLE
13	CONNECTING THE COMMANDLIFT MOTOR TO THE DOOR PLATE
14 - 17	DRILLING AND MOUNTING EMERGENCY RELEASE CABLE
18 - 20	INSTALLING CONTROL BOX AND MAKING ELECTRICAL CONNECTIONS
21	TESTING THE OPERATION
22	ADJUSTING DOOR TRAVEL
23	REMOTE KEY FOB OPERATION
24	USING THE EMERGENCY RELEASE SYSTEM
25	ADDITION FEATURES / AUXILIARY SYSTEMS
26	PROGRAMMING ADDITIONAL REMOTES / CHANGING REMOTE BATTERIES
27 - 29	COMMANDLIFT MAINTENANCE
30	APPENDIX A – DOOR MAINTENANCE
31	APPENDIX B – DOOR PLATE MOUNTING OPTIONS
32	APPENDIX C – LED AND WIRING MATRIX
33 - 36	APPENDIX D – KUSSMAUL LOAD MANAGER INSTRUCTIONS – 3 <sup>RD</sup> PARTY
37	APPENDIX E – DETAILED REMOTE PROGRAMMING INSTRUCTIONS – 3 <sup>RD</sup> PARTY
38 – 41	TROUBLE SHOOTING GUIDE



Issue 011516 (En)

## ***Pre-Installation Check List***

1. Before you begin the installation of your CommandLIFT™, confirm that you have a minimum of 2 inches clearance above the Roll-Up door when it is in the Open position.	YES	NO
2. Has the correct Balancer been installed on your Roll-Up door? Confirm that either a WHITING 2376 or 7176 center bracket balancer has been used.	YES	NO
3. Use the chart below to ensure there is enough clearance between the top of the horizontal track and the ceiling. Is the radius of the track suitable for CommandLIFT™ operation? The CommandLIFT™ might have difficulty with tight radius tracks during the closing cycle.	YES	NO
4. Is the Roll-Up door balanced properly? Does it work easily, UP and DOWN by hand?	YES	NO
5. Is the door in good working condition? Make sure there are no broken panels, hinges or rollers etc.	YES	NO
6. Is the top panel of the door strong enough, or will it require reinforcement to prevent it from “flexing” during the closing cycle?	YES	NO
7. Is the power supply adequate? Has the battery and charging system been well maintained?	YES	NO
8. Will a proper power supply always be available? Will a secondary power supply be required?	YES	NO
9. The CommandLIFT™ is supplied with two Remote Transmitters. Will that be adequate or will alternative transmitting devices be required? (Additional Remote Transmitter – Keypad – Key Switch – Activating button on the dashboard). These items might be useful for dock workers or others who may need access to the cargo area of the truck or trailer.	YES	NO

# IMPORTANT - Before you start the installation

## **POWER REQUIREMENTS:**

The CommandLIFT™ is supplied with approximately 45 feet of cable that runs from the CommandLIFT™ track to the CommandLIFT control module that should be mounted as close to the battery as the CommandLIFT cable will allow.

You will require either 6 gauge or 8 gauge wire to run from the battery to the CommandLIFT control module. 8 gauge wire for runs up to 35 feet long, 6 gauge for runs from 35 to 60 feet. Red and black wires are recommended.

**A 30 amp in line fuse will also be required for connection on the positive wire at the battery connection.**

The CommandLIFT module is equipped with a Kussmaul Load Manager. This device monitors vehicle power supply and turns the CommandLIFT control module off when the incoming voltage drops below 10.5 volts. Using under size wire can result in voltage drop at the module even when the vehicle or battery is providing full current.

There is an output on the Load Manager for an audible or visual alarm.

Please see appendix D for Kussmaul Load Manager instructions.

**WARNING — The gauge of the CommandLIFT cable is determined by the maximum supplied length. Do not splice wires for extra length as this can cause voltage drop resulting in poor / intermittent operation or damage to the system.**

## **Power Consumption:**

An idle CommandLIFT™ will draw 1.5 amp hours from a battery over a 24-hour period. It is recommended that during long periods of inactivity, the CommandLIFT™ be disconnected from the battery.

1. Using the illustration on the next page, plan how you are going to run the wires for the CommandLIFT™.
2. Note that the CommandLIFT Module should be located as *close as the CommandLIFT cable allows* to the vehicles power supply.
3. The control module can be mounted inside the truck body if preferred. Ideally this would be done only when there is an alternate door in the event of low voltage disconnect.

**It is not recommended, but if you are planning to connect the CommandLIFT™ to an existing Reefer Unit or Lift Gate power supply – consult with Whiting Door and the reefer or lift gate supplier first!**

Today's refrigeration units are equipped with sophisticated electronics and control systems. The integrated logic of these systems monitors the condition of the battery and isolates accessories when the battery drops below pre-determined levels. For trailer applications it is strongly recommended that you utilize the Purkeys Trail Charger system to ensure your new CommandLIFT™ works as intended. For more information on the Purkey's trail charger system and pricing contact you Whiting Door representative.

## Insulated Truck Bodies or Trailers

If the CommandLIFT™ is going to be installed in an Insulated truck body or trailer, you must ensure that strips of wood or metal spacers are securely fastened to the roof bows and extend down to the ceiling of the body. Do not fasten the CommandLIFT™ aluminum track to the ceiling liner of an insulated roof. This will not be strong enough to support the weight of the CommandLIFT or the force that is required to open and close the door.

## Twin Spring Balancer Maintenance

The CommandLIFT™ was designed to operate with any WHITING® roll-up door, provided the door is equipped with a twin spring balancer and the door has been properly maintained and balanced. The CommandLIFT™ can also be used with other roll-up door systems but some modifications to the trailer or truck body header may be required.

**Check to make sure the roll-up door is properly balanced.**

The CommandLIFT™ will operate the roll-up door provided a force of no more than 50 pounds is required to open or close the door.

Ensure that the force required to lift the door is equal to the force required to close the door.

If the door requires more force to open than it does to close, increase the tension on the balancer.

If the door requires more force to close than it does to open, decrease the tension on the balancer.

Time and the elements affect the tension on the spring that lifts the door. Over time, the spring wire will corrode and loose effective wire diameter. The springs themselves also get tired and loose their tensile strength.

An average balancer on a WHITING® door will last approximately 15,000 to 25,000 cycles.



If your roll-up door is NOT in proper balance, follow the procedure on the next page.

# Adjusting and Maintaining the Proper Door Balance

Always lubricate your roll-up door using WHITING® Easy-UP™ spray lubricant prior to checking the balance of the door. Never use grease in the tracks. Tracks should be clean and dry.

1. Fully open the roll-up door and push it back towards the front of the trailer approximately 18", this may require the assistance of another person or a spreader bar placed between the header and the bottom panel of the door.
2. Install vice grip pliers into the track at the bottom roller to hold the door in this open position while working on the balancer.
3. The springs should have equal tension, for this reason it is important to count the number of turns either put on or removed from each spring, this is easily done by placing a mark on the winding anchor before doing any adjustments.
4. Insert a 3/8" diameter rod (see illustration on previous page) into one of the holes on the winding cone` and carefully remove the center balancer clamp. Lower the winding bar to add tension or raise the winding bar to remove tension. Insert the second winding bar into the next hole on the winding anchor and repeat the process until the desired tension is achieved. The amount of tension to be added or removed depends on the type of door, the age of balancer and how far out of adjustment it is. Adjust the springs no more than one half turn at a time.
5. Replace the balancer clamp and nuts, remove the winding bars.
6. Remove vice grip pliers from track and test the door operation.



**Caution — work on doors and related parts can be dangerous. It is strongly recommended that repair service work be performed by persons who have successfully completed appropriate training. If assistance is required, please contact WHITING® for a list of qualified service locations.**

## Mounting the Door Plate

1. See appendix A at the back of this manual for detailed drawings of various options for mounting the plate on different types of doors.
2. Measure the width of the roll-up door and mark the centerline of the door on the top panel.
3. Rest the mounting plate on the top of the door and slide the plate left or right until the connecting tab lines up with the centerline of the door.
4. Use the mounting plate as a template and drill only the five (5) holes shown below, in the door panel and mount the plate with the fasteners provided.

**Note:** Some composite and hollow doors will require additional mounting hardware in order to provide extra strength for the installation of the door plate assembly. This additional hardware is only included in CommandLIFT™ kits that are manufactured for these types of doors.

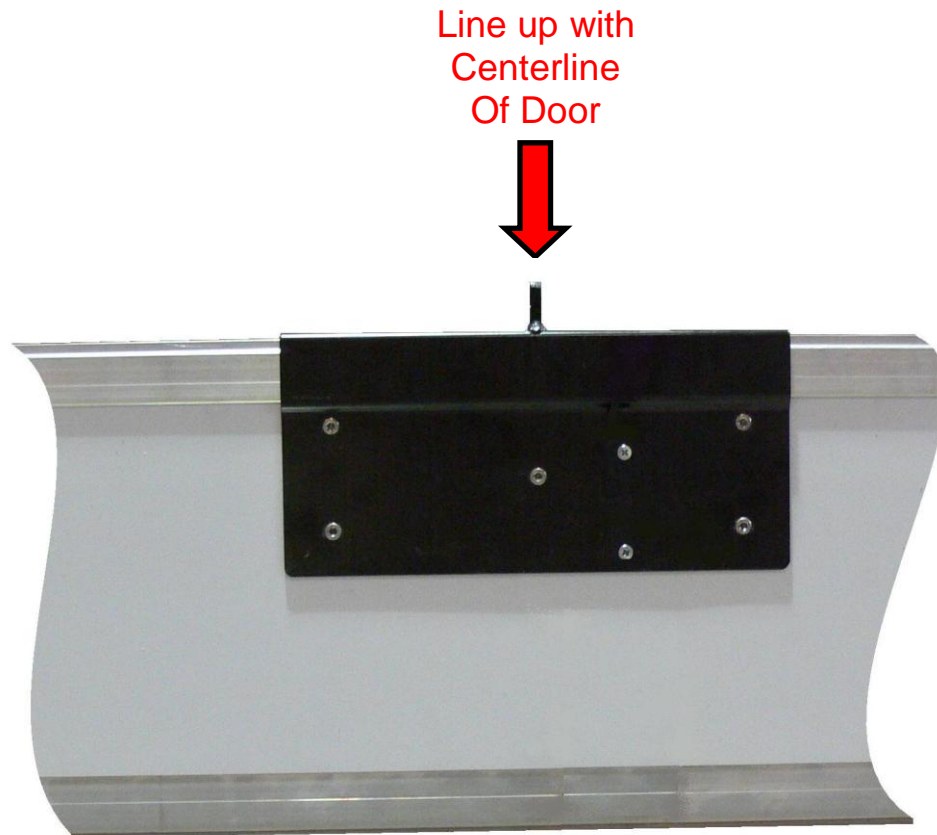

## Changing the Balancer Center Bracket



1. Using a 1/2" wrench, undo the two nuts on the Balancer Center Bracket that is located at the mid point of the WHITING® balancer.
2. Insert a 3/8" diameter rod into one of the round holes on the Balancer spring winding cone. Hold this rod tightly so the balancer spring does not unwind when the Balancer Center Bracket is removed.
3. Remove the old Balancer Center Bracket and replace it with the one in the CommandLIFT™ box.
4. Tighten the 1/2" nuts and confirm that the door is still properly balanced.

### **Note:**

**This step can only be done if the roll-up door operates with two balancer springs as shown above.**

**If your door only has one balancer spring, you will have to make any necessary modifications in order to fasten the CommandLIFT™ track firmly to the header. Do not rely on the rear roof bow to support the CommandLIFT track and motor. This will result in damage to the roof and CommandLIFT.**

## Disengaging the drive motors for manual movement of the motor housing in the CommandLIFT track.

It will be necessary to move the motor to various positions in the guide rail during installation. This is done by opening the small black cover on the motor housing and moving the lever towards to back end of the track as shown in the photo. When re-engaging the motors it is important to push the lever until it makes a distinctive click.

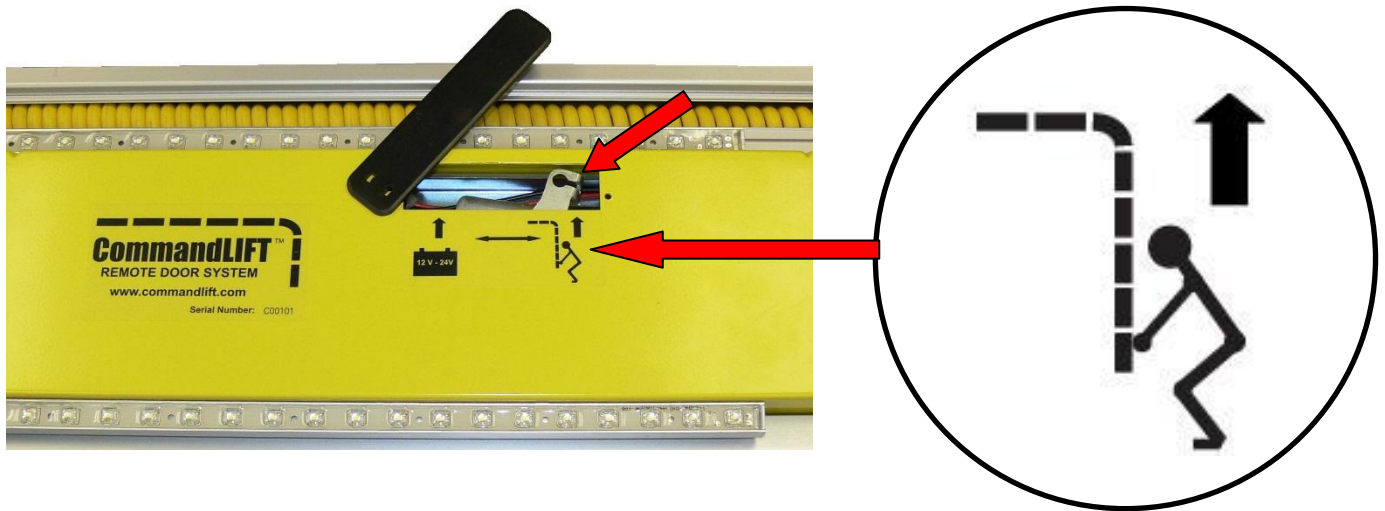

## Joining the two lengths of CommandLIFT™ aluminum track together.

Depending on how your CommandLIFT™ was ordered, the aluminum track will be shipped in either one or two pieces. If the track was delivered in one piece, continue on to the next step: **Connecting the track to the Header Bracket.**

If the track was delivered in two pieces, follow the next steps to join the two tracks together.

1. Remove the black plastic cover from the side of both track sections.
2. Line up the two pieces of track on a straight, level bench or work surface.
3. Using an Allen wrench, undo the six screws (both sides) that are holding the joiner slides in the rear track section.



4. Pull the two track joiners halfway out of the rear track section and lightly tighten the two front screws



5. Slide the front track over the two joiner pieces and ensure that the two tracks are butted together snugly.
6. Make sure the two tracks align properly and there are no sharp edges at the joint. Sharp edges at this location will cause premature wear to the motor sliders.
7. Tighten down all the screws and once again, check for fit and alignment.
8. Find the long sensor wire that has been coiled and secured to the rear track section, and connect it to the sensor that is located in the front track section. The position of this sensor will need to be adjusted later in the installation.

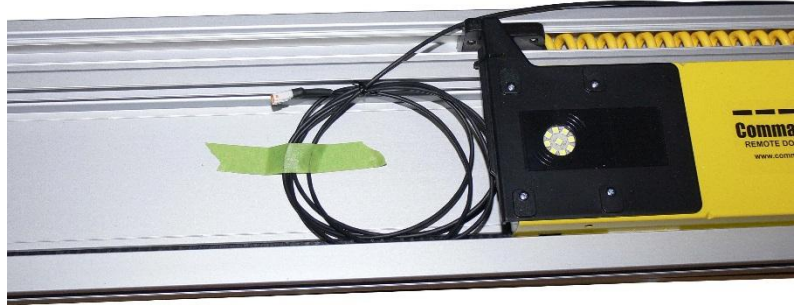

It is not recommended but if the length of the aluminum track has to be reduced for any reason, the cut must be made at the front of the track (furthest from the door opening). Replace the “Stop Screw” that was cut off of the track. The shortest length of track required for the CommandLIFT™ to operate properly is: **door height plus 36 inches.**

# Connecting the track to the Header Bracket



Connecting the track to the header

1. Disengage the motor unit in the track by moving the lever to the manual position and slide the motor all the way towards the front of the truck body. Pick up the back of the CommandLIFT™ track assembly and fasten the adjustable mounting bracket to the balancer center bracket that you installed on the balancer shaft in the previous step.



Adjustable Header Bracket

2. Slide the motor back to the back of the truck, close to the header and lock it in place. If necessary adjust the header bracket left or right to ensure the tab on the top door panel and the tab on the CommandLIFT™ motor unit are lined up as closely as possible. Once the two tabs are lined up, retighten the adjusting bolts in the header bracket so the track assembly won't move while it is being fastened to the roof bows or ceiling.

## Fastening the CommandLIFT™ track to the roof bows



1. Using “Jack Stands” or some other suitable method, lift the front end of the CommandLIFT™ track up to the ceiling or roof bows.

2. Measure from the edge of the body roof to the edge of the CommandLIFT™ track (at the header).

3. Adjust the other end of the track and confirm that the same measurement is used along the entire length of the track.

4. Tighten the stands to ensure the track will not move while it is being fastened to the roof bows. It is critical that the CommandLIFT™ be installed parallel to the sides of the trailer or truck body.

5. Using a suitable bit, drill holes in every roof bow along the entire length of the CommandLIFT™ track.

6. IMPORTANT - Use the two grooves in the track to locate the positioning of your fasteners.

7. Use two fasteners at every roof bow.

8. A large diameter head screw or blind rivet, with a head depth of less than 1/4" is recommended.

9. Slide the CommandLIFT™ motor unit by hand along the entire length of the track. Watch and feel for any obstructions or resistance during the travel. Make sure the fastener heads are not too large and pay particular attention to any waviness in the track. If the CommandLIFT™ binds because of a wavy track, use shims to make sure the track is level and straight.



Drilling the roof bows

10. Once the track is secure and straight, tighten all the nuts and fasteners at the Header Bracket.

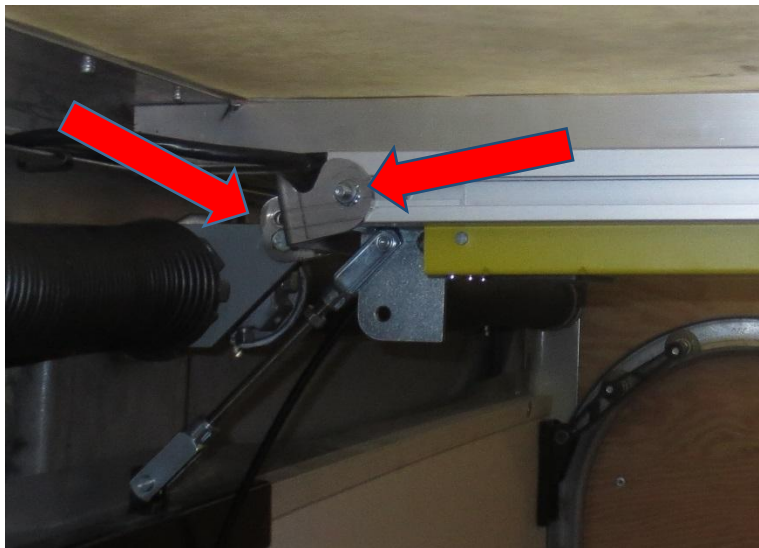

## Connecting the CommandLIFT™ to the Roll-Up door

1. Slide the CommandLIFT™ motor unit towards the door, as far as it will go, then slide it back approximately 3/4 inch away from the stop screw.
2. Make sure the roll-up door is in the fully closed and locked position.
3. The turn buckle connecting rod used to join the door to the motor assembly needs to be adjusted for optimal length and position. With the motor in the closed position and the door closed hold the rod up to the holes in the tab on the door connection plate and the lower hole on the puller bracket of the motor. Ideally with the door closed the angle should be 30 – 45 degrees. If there isn't enough angle using the lower hole, try the upper hole. If the rod isn't pushing down on the door it won't close properly, but with the door open the rod should be as horizontal as possible. Once you have determined which hole on the puller bracket you will connect to go to step 4.
4. Measure the distance between the hole from step 3 on the motor unit puller bracket and the hole in the tab on the door plate and cut the threaded connector rod 1" shorter than this measurement.
5. Install the turn buckle. Tighten the nut on the threaded rod up against one of the forks on the assembly to prevent the rod from vibrating out of position.
6. The turn buckle assembly should be resting at approximately 30 - 45 degrees.
7. Open the roll-up door by hand and confirm that everything operates smoothly.

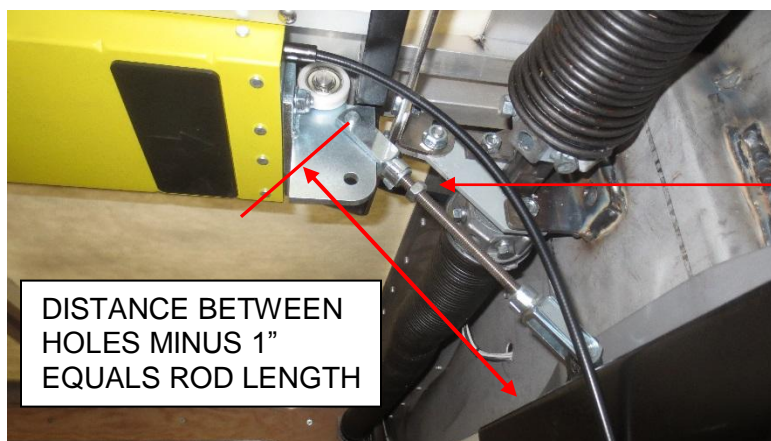



# Drilling the Holes for the Emergency Release

- 1. Measure the width of the roll-up door and mark the centerline of the door on the first panel below the top panel.
- 2. Find the paper template in the CommandLIFT™ box. Remove the paper backing and stick the template to the second panel.

Line up this edge of template with the top edge of the second door panel.

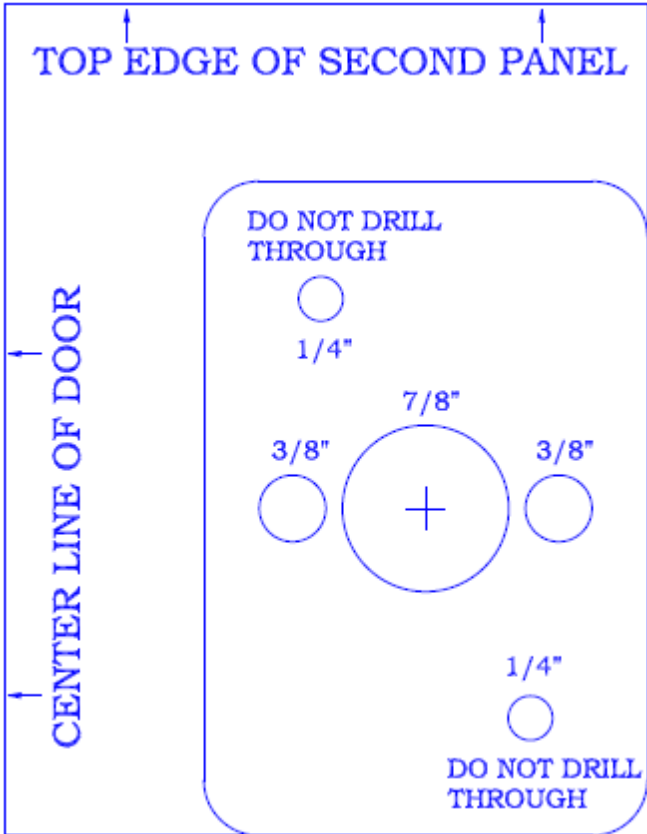

Line up this edge of template with the top edge of the panel adjacent to the top panel.

Drill Diameter	Notes
----------------	-------

3/8" diameter	Drill holes (2) completely through the door panel
1/4" diameter	These are clearance holes and should be drilled no more than 1/4" deep. (Do NOT drill completely through the door panel).
7/8" diameter	Use a hole saw and drill hole through the door panel

3. Remove the template from the door panel if you wish, or mount the plate directly over the template.

## Connecting the EMERGENCY release cable

1. Locate the lock assembly, turn the key 90 degrees and remove the core of the lock from the lock housing plate. Insert the housing plate into the holes on the face of the door. Use masking tape if necessary to hold the housing to the face of the door.
2. Select the appropriate length screw from the chart and secure the interior mounting plate to the housing, ensuring the small holes on the corners are aligned with the clearance holes.
3. Insert the end of the cable with the stop into the guide tube at end of the motor housing, push the cable through until you can see it in the opening where the release lever is. Insert the stop through the release lever and engage the lever (lock the CommandLIFT motors), with the lever engaged push the cable 2" further into the motor.



4. Slide the cable sleeve over the cable and into the cable guide tube in the motor housing 2". Mark the sleeve 1" below the door connector plate. Remove the sleeve from the cable and cut it on the mark. **DO NOT CUT THE CABLE**. Slide the sleeve back over the cable and into the motor housing. Use the two ½" Phillips machine screws to secure the cable clamp to the door connector plate.

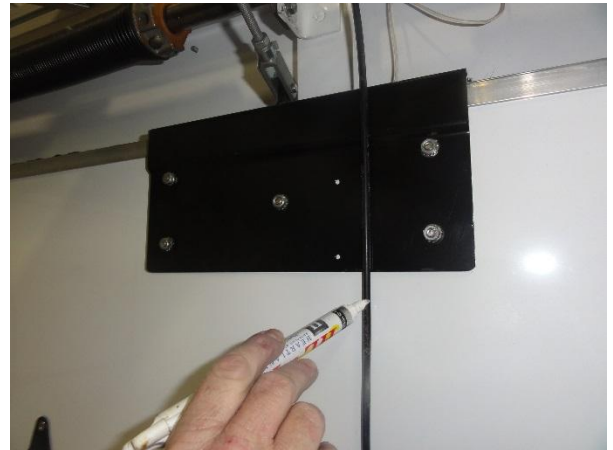

5. **Ensure the cable is still two inches past the release lever and the lever is still engaged.** Using good quality cutters cut the cable 1" below the lock mounting plate. Not using a proper tool to cut the stainless cable can cause the end of the cable to fray and become difficult to insert into the lock.

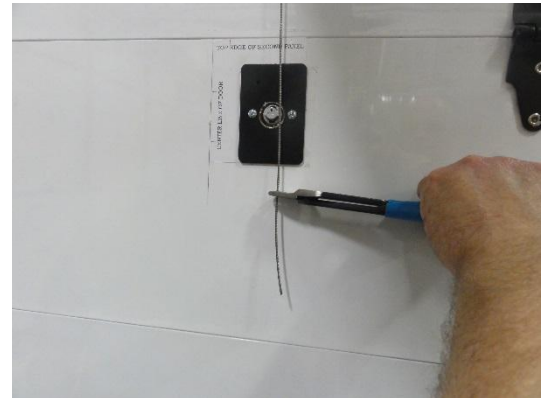

6. Slide the yellow tube, the 2" piece of cable sleeve and the plastic cover base over the cable. Push the cable through the door and lock housing so it protrudes through the face.
7. Insert the cut end of the cable into the hole on the back of the lock core. Secure the cable by tightening the set screw on the side of the core with a 5/64" Allen key. Be sure it is a tight as possible. Insert the core into the housing, turn 90 degrees and remove the key.





8. Use the two screws provided to secure the exterior cover over the lock assembly.



9. Locate and secure the rear cable cover on the mounting plate using the two 1" Phillips machine screws provided. This cover also acts as a clamp for the 2" section of cable sleeve.

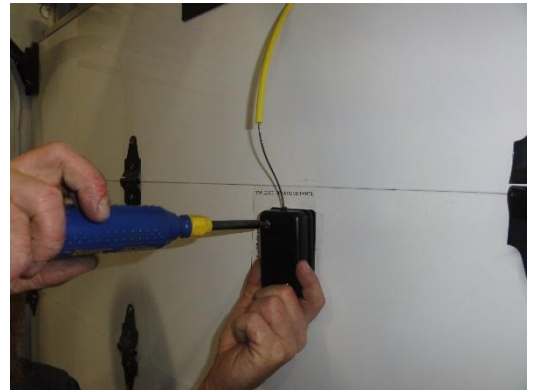

**At this point the mechanical installation is complete and you are ready to move on to the electrical installation.**

**Use the diagram below to determine the ideal location of the control module for your installation. As close to the battery as possible.**

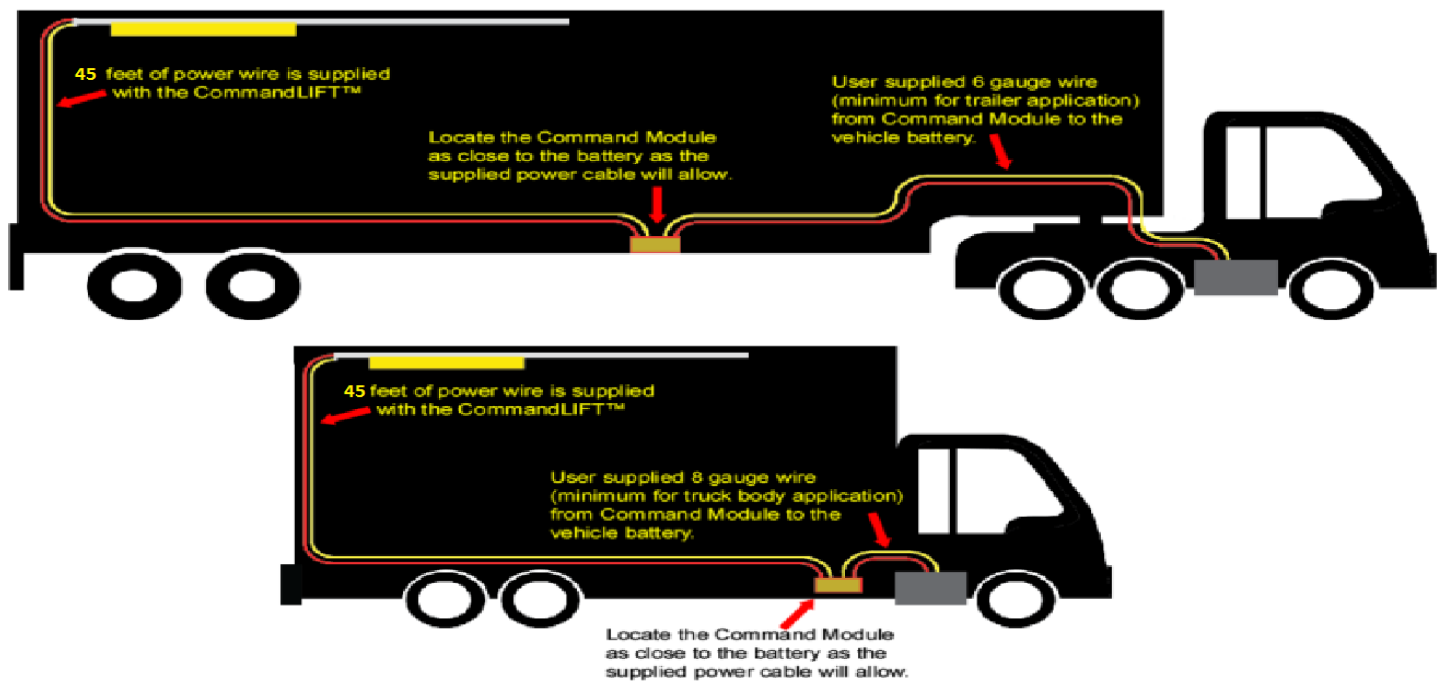

## Routing the Supply Wires to the Command Module

**IMPORTANT! ALWAYS MOUNT BOX WITH CABLE GLANDS TO THE BOTTOM.**

The CommandLIFT™ is supplied with a 45 foot, 6-wire power and communication cable, which has been pre-connected to the CommandLIFT™ track at the factory.

The CommandLIFT Module (electronic box) should be located as close as possible to the 12 volt, 30 amp power source as possible.

In a typical installation, the CommandLIFT cable might run along the header, and down along the side wall. From there, the cable would be routed under the truck body or trailer as far forward as the cable will allow.

At this point, find a safe and convenient location to mount the Command module box. Even though the Command module box has an NEMA 4X, IP68 rating, it should be located in as protected a location as possible.

Inside the control module you will find 2 key fobs, 2 cable eyelets and 4 mounting tabs. The key fobs are programmed for this box, do not mix them up with fobs from other units. Install the mounting tabs on the back of the module with the 4 screws provided. Using some type of thread lock, Loctite, on the screws is recommended.



There are three cable glands on the bottom of the Command module box. **Be sure to mount the box with the wire openings towards the bottom.** Mount the box onto the vehicle. Route the cable from the CommandLIFT up through one of the cable glands. Ensure there is enough wire to reach the terminal strip inside the box. Tighten the clamp nut on the cable gland. This nut has to be tight enough to provide a water-tight seal around the wire



Two 8 or 6 gauge wires will be required to connect the Command module to the battery, one red and one black. These two wires are not included with the CommandLIFT. If the wire run doesn't exceed 35 feet in length, minimum 8 gauge is required. If the wire is longer than 35 feet, 6 gauge is required. Feed the two power wires up through the remaining two cable glands.

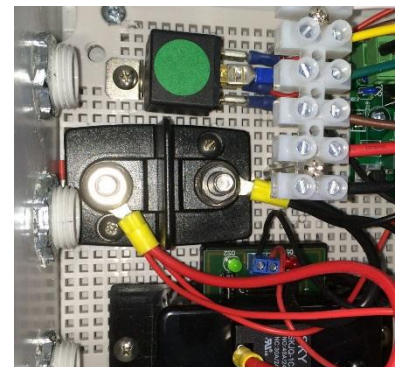

Crimp the supplied cable eyelets to the power wires and secure them to the posts as shown on the right.

**NOTICE** – Connect the red wire to the corresponding red terminal on the block and the black wire to the black terminal. Using supply wires of a smaller gauge than mentioned above may result in the Load Manager going into alarm mode and the CommandLIFT will not operate.

## Wiring the CommandLIFT cable

The CommandLIFT cable contains six wires. The white, yellow, brown and green wires are smaller gauge than the red and black wires. Study the illustration below, and route the smaller gauge wires to the terminal strip and connect the white wire to the existing white wire, the yellow wire to the existing yellow wire, the brown wire to the existing brown wire and the green wire to the existing green wire.

The red and black wires should be connected to the existing red and black wires at the end of the terminal strip. Make sure all connections are solid and secure.

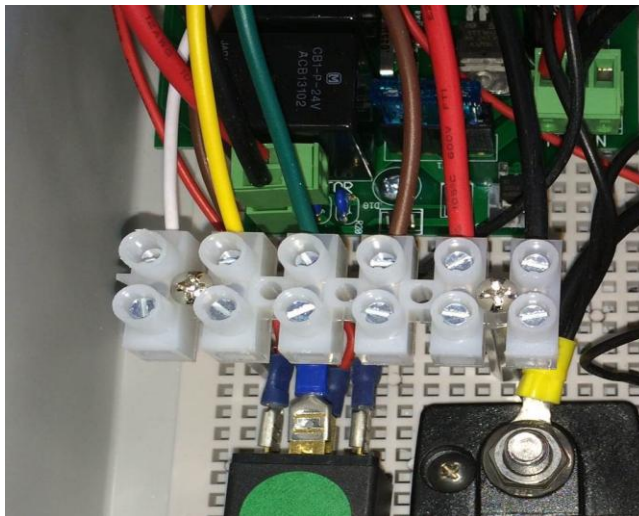

Once all connections inside the box are secure be sure to tighten the cable gland nuts. The wires should be secure and not able to pull through the nut once tightened.

## Connecting to the 12 volt battery source

When you are satisfied that all the connections to the Command Module are tight and secure you can now connect the battery. Make sure the positive lead **RED** from the Command module is connected to the positive post on the battery and has a 30 amp inline fuse. The negative lead **BLACK** is connected to the negative post on the battery. Connecting the wires on the wrong terminals can permanently damage the CommandLIFT electronics and will not be covered under warranty. Make sure these connections are secure. Protect the connections from the elements by applying silicone grease or some other type of sealant to the connections.

## Engage the Motor Unit and test the door



Before engaging the motors, position the door so the CommandLIFT is between the open and closed sensors. These are found on the road side of the CommandLIFT track. Once the CommandLIFT is between these sensors you can lock the motor into position by engaging the drive lever. Open the black access cover on the motor unit and you will see a metal lever. Insert a screw driver

in the hole on this lever and pull the lever towards the front of the body (away from the door opening) until the lever **“SNAPS”** into place at the location shown to the right.

You may have to use a screw driver or other suitable tool to help you move the lever into place. The motor unit is now locked into place in the track. Replace the access cover.

**Check the installation of the CommandLIFT™ once again, and when you are satisfied that the installation is complete and secure, and all the fasteners and electrical connections are tight and secure, press the open button on the Remote Control transmitter.**

The door will move upward. Pressing this button again, will STOP the door travel.

Note: On power up of the system the first command has to be open. The close function does not operate upon initial power up.

## Adjust the door travel

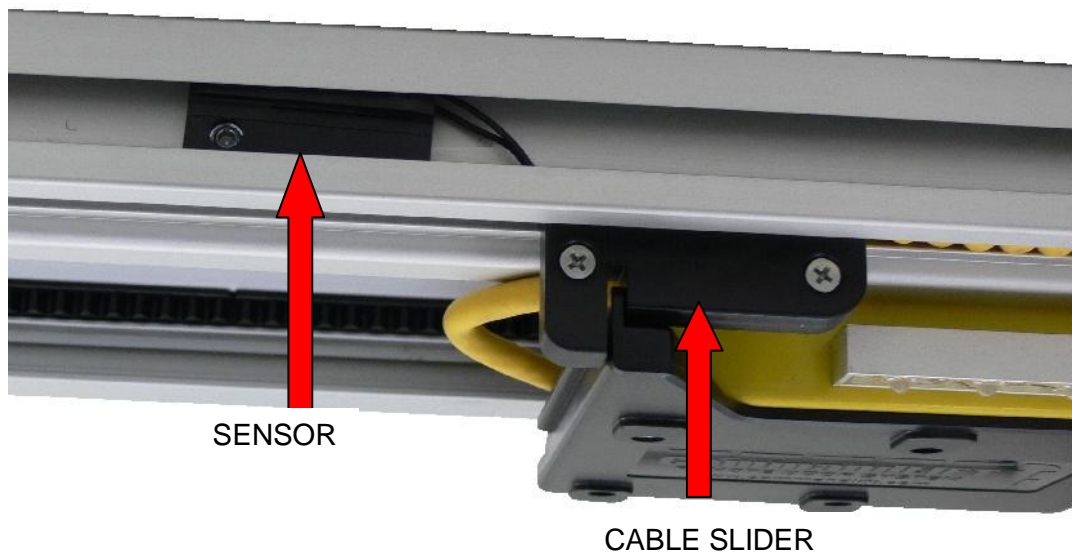

On the road-side of the aluminum track, you will see two sensors that are each held in place with a set screw. The sensors are simply normally open Reed switches that are closed when the magnet in the cable slider passes over them. You will have to remove the plastic, finishing strip from the aluminum track in order to see these sensors. These sensors tell the **CommandLIFT™** how far to travel before stopping by sensing the magnet inside the slider.

To set the sensor for the door CLOSED position, close the door all the way and lock it with the door lock. Slide the sensor so it rests just above the cable slider. The LED light indicating “door closed” should be illuminated in the Command module.

To set the sensor for the door OPEN position, open the door all the way. Loosen the set screw on the OPEN sensor and slide it in the aluminum track until it rests about 2” in front of the cable slider. My setting it 2” beyond the cable slider the CommandLIFT will pull the door all the way open beyond and above the bottom of the header. This will provide a FULL door opening on the truck body or trailer. The “door open” LED on the board should be illuminated.

Don't forget to place the CommandLIFT™ **CAUTION** label above the door grab handle, just above the pull strap. This label reminds operators that the door will probably not operate normally and that they must use the Remote Control Transmitter in order to activate the door, or use the key on the EMERGENCY Release system in order to operate the door manually.





## What happens when the Remote Control Transmitter button is pressed?



**OPEN**



**CLOSE**

1. When the remote control button with the unlock  icon is pushed, the door will start to open. After the door is in the open position, the LED lights on the CommandLIFT™ motor unit will turn on. The lights will stay on (with the door open) for fifteen minutes.
2. When the remote control button with the lock  icon is pressed, the door will close. After the door is in the closed position, the LED lights on the CommandLIFT™ motor unit will turn on and will stay on for one minute.

3. If you press the either of the remote control buttons while the door is in travel either up or down, the door will STOP.
4. If the roll-up door hits an object (such as a box or other cargo) while it is closing, the door will stop moving and go back up approximately three inches allowing the obstacle to be removed. The safety logic requires that you press the open button to remove the obstacle, pressing the close button will not activate the door. If the door is obstructed while opening it will stop, but not reverse.
5. Make sure the roll-up door lock is in the UNLATCHED position before the CommandLIFT™ is operated.

## Using the EMERGENCY Key Release system

You may be occasionally required to release the CommandLIFT™ from the door system in order to operate the Roll-Up door manually. CommandLIFT™ can be released from the drive system in two ways.

### Using the exterior EMERGENCY release

1. Insert the CommandLIFT™ key into the lock cylinder located in the center of the second roll-up door panel from the top.
2. Turn the key 90 degrees and pull the lock and connecting cable from the lock cylinder. Pull the lock assembly *firmly* and the CommandLIFT™ will be released from the drive system.
3. Reinsert the cable and the lock cylinder back into the lock housing on the door. The roll-up door can now be operated manually.



### Using the interior EMERGENCY release

1. Pull on the yellow section of the cable coming from the CommandLIFT to the door. 
2. Now the door can be operated manually.

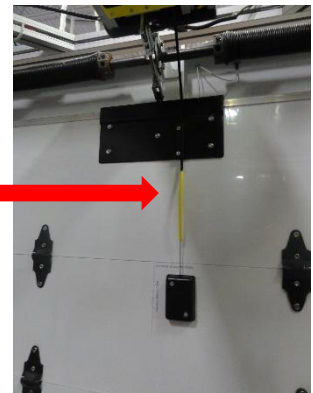

### Reconnecting the CommandLIFT™ drive system

1. Open the Access Panel on the CommandLIFT™ motor unit.



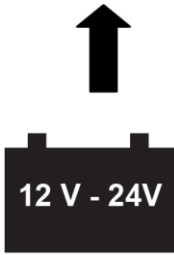

2. Push the lever towards the front of the body (away from the door opening) until the lever “SNAPS” into place. You may have to use a screw driver or other suitable tool to help you move the lever into place. The motor unit is now locked into place in the track. Replace the cover on the access panel. CommandLIFT™ can now be operated with the Remote Control transmitter.

THE COMMANDLIFT WAS DESIGNED TO OPEN AND CLOSE THE ROLL UP DOOR. IT WILL DETER THEFTS OF OPPORTUNITY BY MAKING THE DOOR DIFFICULT TO OPEN. IT IS NOT DESIGNED TO BE A LATCH FOR SECURING THE DOOR WHILE THE TRUCK IS IN MOTION. NOT LATCHING THE DOOR BEFORE MOVING THE VEHICLE CAN DAMAGE THE GEARS, THE TURN BUCKLE AND THE CEILING OF THE VEHICLE. DAMAGE OF THIS NATURE IS NOT COVERED UNDER ANY WARRANTY.

Standard installations. If you wish to utilize any of the following features refer to the CommandLIFT website or contact Whiting CommandLIFT support for further instructions.

- Low voltage alarm – CommandLIFT will not operate.
- Door open alarm – Alerts the driver to close the door.
- Cab or cargo area switches – Hardwired switches to open / close the door.
- Ignition lockout – Closes the door and blocks operation when vehicle ignition is on.

## Integrating Auxiliary Systems with CommandLIFT®

Integration of the CommandLIFT® system with other operating systems may only be done with express written consent of WHITING Door. Failure to do so will void all warranties. Consult with your dealer or the factory before connecting any other systems to the CommandLIFT® controller.

### Conditions

Connection must be as outlined in the CommandLIFT® manual as well as the specific installation instructions from the integrated accessory.

WHITING warranty against manufacturing defects is limited to the CommandLIFT® motor unit, the control module and any supplied cable.

WHITING Door will not be held responsible for any components or related labour to any auxiliary systems as a result of integration with the CommandLIFT®.

Damage to the CommandLIFT® controller as a result of connection to an auxiliary controller is not covered and is the responsibility of the supplier / manufacturer of the secondary controller.

Under no circumstances can the CommandLIFT® control module be used as a power source or junction point for any auxiliary systems or controllers.

Damage to the mechanical drive system, track, electronic module or wiring through improper operation of the CommandLIFT® in conjunction with any auxiliary systems is not covered under warranty.

Any damage as a result of forcible entry is not covered under the warranty.

WHITING Door reserves the right to review and retract if necessary the consent if the configuration of the various systems deviates from the original design and approval.

## Troubleshooting with Auxiliary Systems

When CommandLIFT® is used with a controller other than the originally supplied CommandLIFT® FM receiver the first step in any troubleshooting scenario is to check for power to the CommandLIFT® controller and auxiliary controller.

Once power has been verified the second step is to disconnect the auxiliary inputs to the CommandLIFT® controller and reinitiate the FM receiver. Test the CommandLIFT® with the originally supplied receiver and key fob remotes. If the CommandLIFT works with the original receiver and remotes the problem is with the auxiliary system.

Contact the supplier / manufacturer of that system.

## Programming Additional Remote Control Transmitters

The CommandLIFT™ comes with two Remote Control transmitters that are pre-programmed for your motor unit. The CommandLIFT™ will allow additional Remote Control transmitters to be programmed to the motor unit. These additional Remote Control transmitters must be programmed into the CommandLIFT™ system by following these steps:

1. Remove the inline fuse at the battery.
2. Wait approximately 5 seconds.
3. Reinsert the fuse and within 5 seconds press both buttons on the key fob remote simultaneously. The receiver will enter the learn mode. Release the two buttons.
4. Press the unlock (open) button on all key fob remotes that you wish to enroll to that receiver.
5. Once all key fobs, wall switches, keypads have been enrolled the receiver will exit learning mode after 5 seconds of inactivity.

For additional information refer to appendix E

## Changing the Battery in the Remote Control Transmitters

If the Roll-Up door does not operate when the button on the remote control transmitter is pressed, check to ensure the red light on the transmitter lights up when the button is pressed. If it doesn't light up the battery in the transmitter needs to be replaced.

Use a small coin or flat blade to pry the back off the transmitter and replace the battery.

The CommandLIFT uses an A23 battery available at most battery retailers or through your Whiting distributor.

# CommandLIFT™ Maintenance

There are only a few maintenance procedures that should be completed on a **monthly** basis.

1. Using WHITING® brand EASY-UP™ spray lubricant, completely lubricate the EMERGENCY key lock located on the Roll-Up door.
2. Inspect and clean the Aluminum track. If the track assembly was shipped in two pieces, make sure the track joint is flush and remove any sharp edges.
3. Make sure the Motor Unit slides smoothly in the track.
4. Check all the wiring connections to make sure they are clean, safe and secure.
5. Check the Plastic Motor Unit Guides and replace them if they show any signs of wear (see below). These Guides are available from a WHITING® dealer.  
Ask for Plastic Motor Unit Guides  
Part No. – CLA-0116 (Set of 4).



## Replacing the Plastic Guides on the Motor Unit

1. Remove the **CommandLIFT™** Motor Unit from the aluminum track as per the directions on the next page.
2. Remove the four Plastic Motor Unit Guides from the Motor Unit housing.
3. Inspect the Plastic Motor Unit Guides and replace them if they show any signs of wear.



Plastic motor unit guides

## Motor Unit removal for Servicing

If the CommandLIFT™ has to be removed from the track for regular maintenance, follow these steps:

Open the door and remove the turn buckle assembly from the motor unit.

Remove the front STOP screw from the track at the end furthest from the door opening.

Disengage motors as illustrated on page 7.

Remove the emergency release cable assembly from the release lever in the motor unit.

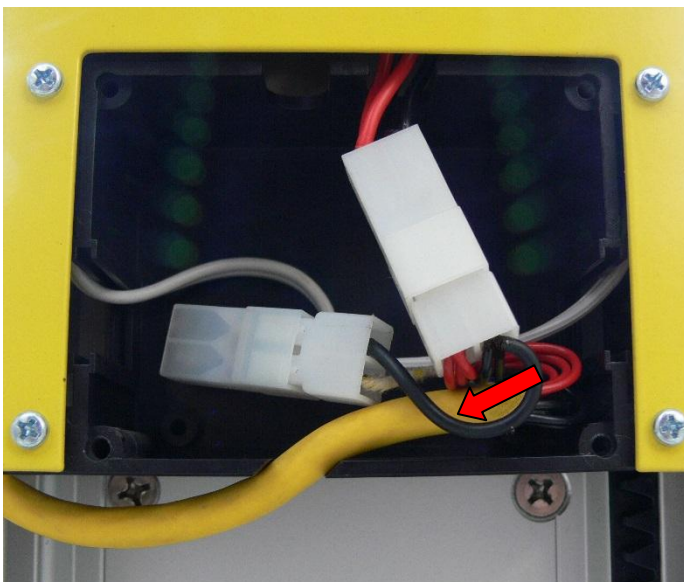

Remove the four screws from the large black cover with the light on the CommandLIFT™ motor unit. Unplug the two connectors in the motor unit and slide the CommandLIFT™ motor unit out of the aluminum track (see illustration below).

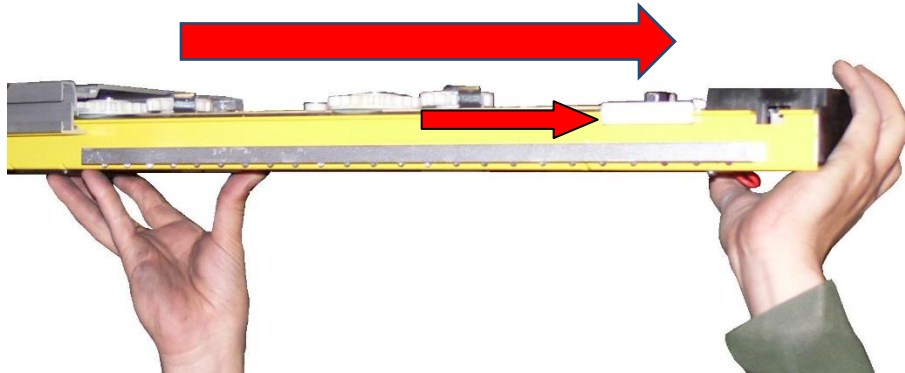

## Reinstall Motor Unit

If the CommandLIFT™ was removed from the track for regular maintenance, complete the following steps to reinstall the CommandLIFT™ motor unit into the track.

Slide the CommandLIFT™ motor unit back into the end of the aluminum track.

Plug in the two wiring harnesses that are located in the plastic box on the motor unit (refer to illustration on the previous page).

Replace the black plastic cover on the motor unit (see illustration below). Make sure the tab on the cover fits into the slot on the coil cable slider assembly, and replace the 4 mounting screws on the cover.

### Important!

Replace the small zip tie that secured the yellow cable to the lid of the motor unit. Failure to replace the tie can result in the yellow cable wearing on the aluminum track during travel.

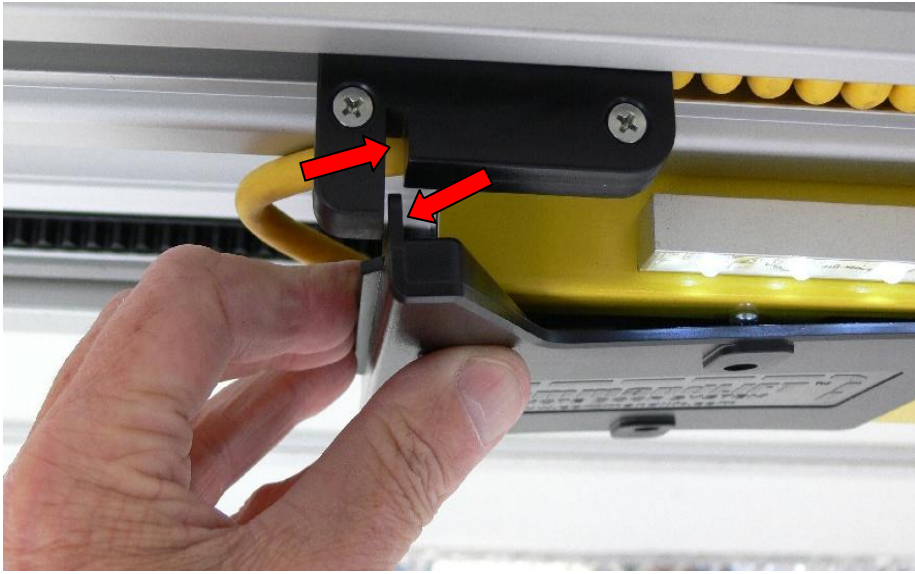

Replace Cover Plate

**Appendix A - [WHITING® Roll-Up Door Maintenance Procedure](#)**

Lubricate the roller bearings and shafts, hinge pins and cable drum bearings as per the illustrations below.



**DO NOT USE GREASE OF ANY KIND!** Grease sits on the surfaces and attracts dust, dirt and salt. The recommended lubricant is environmentally friendly, WHITING® brand EASY-UP™ spray lubricant available from your local WHITING® dealer



## **Appendix** **Mounting the Door Plate**

**B**

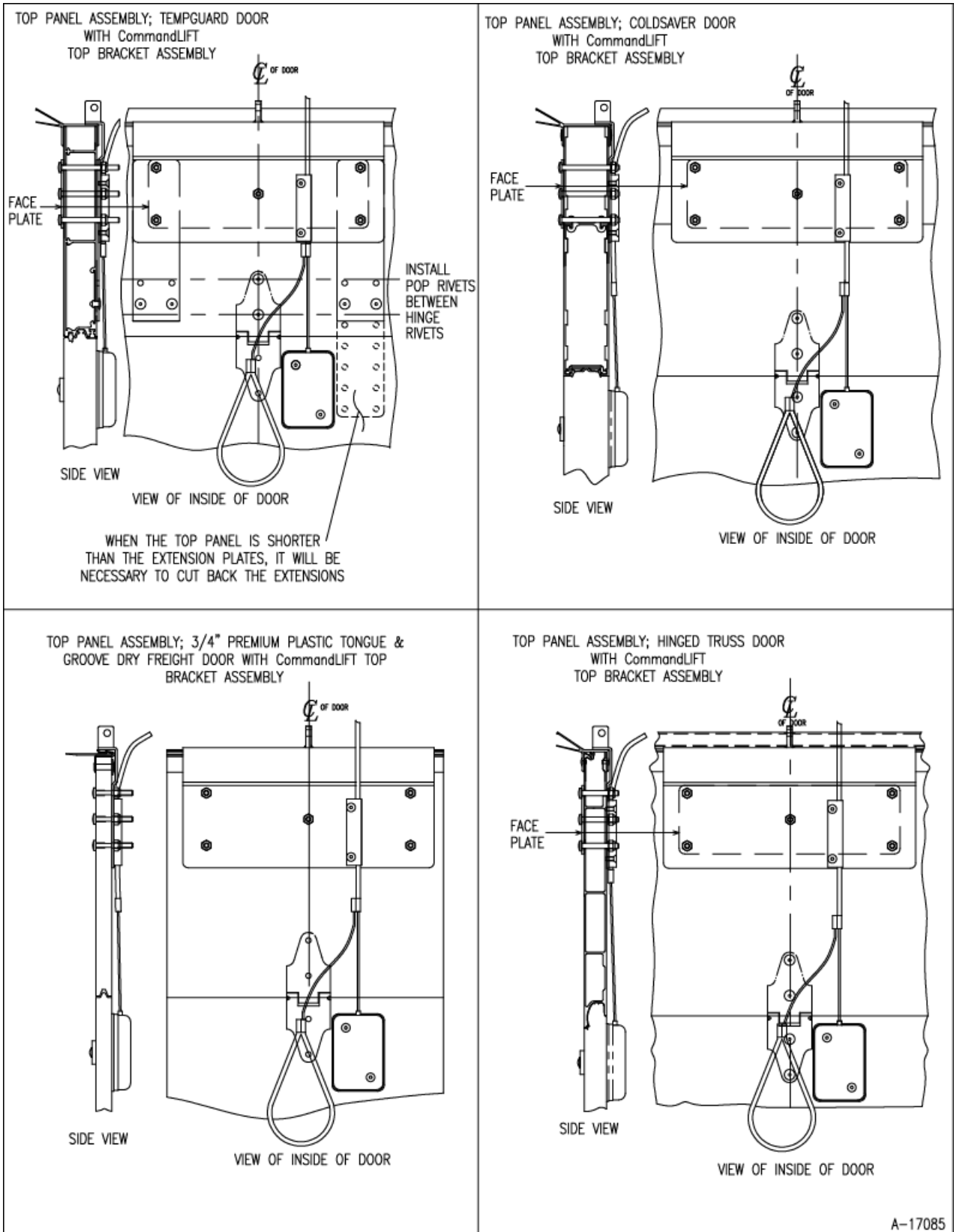

A-17085

**Note: Cable assembly is not as illustrated.**



### Circuit board LED matrix.

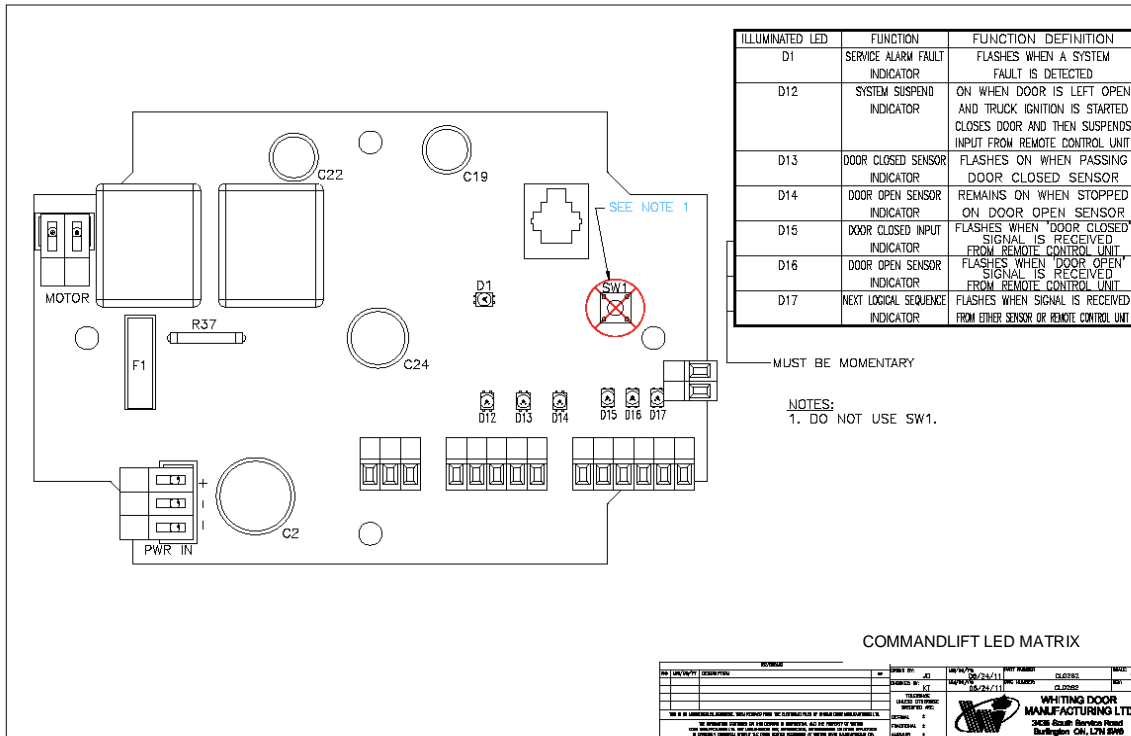

COMMANDLIFT LED MATRIX

REV	DATE	BY	CHKD	APP'D	DESCRIPTION
1	02/26/11	KT	KT	KT	ISSUE FOR PRODUCTION

WHITING DOOR MANUFACTURING LTD.  
3435 South Starvation Road  
Burlington, ON, L7M 5W6

### Circuit board wiring matrix.

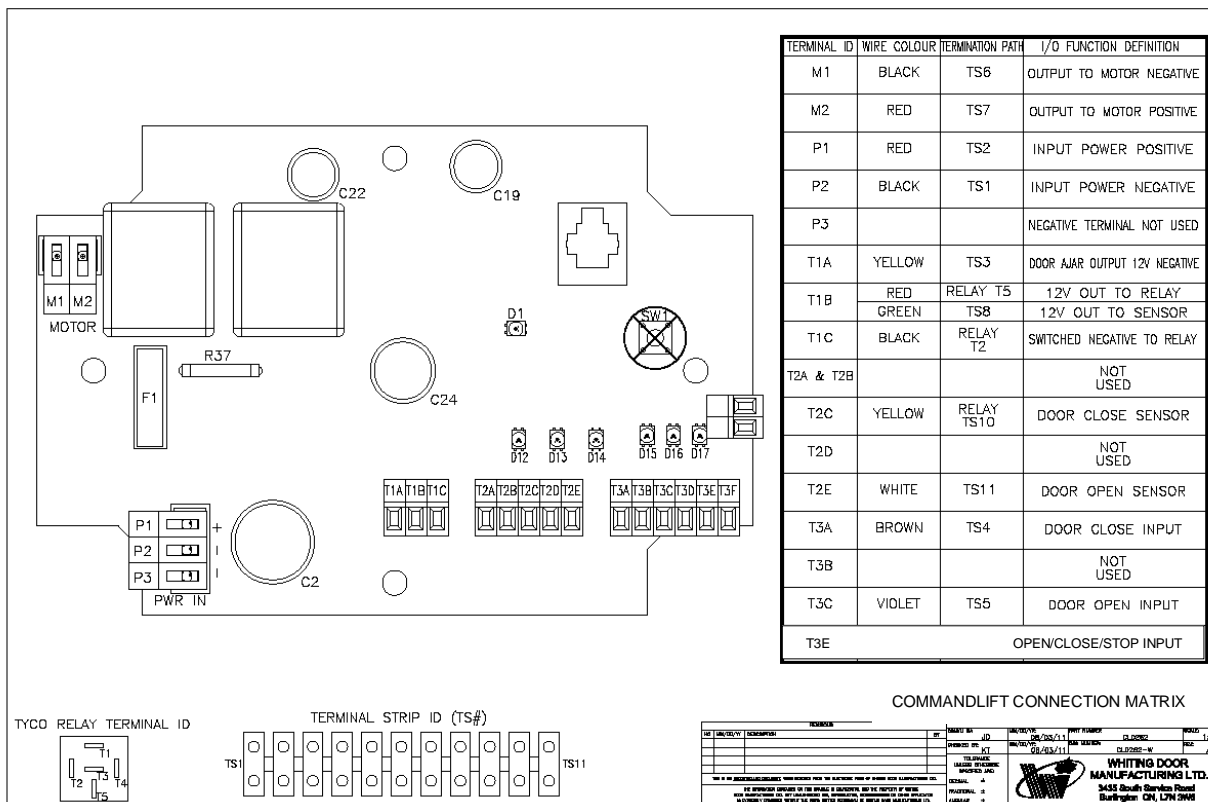

### Appendix D – Kussmaul Load Manager

INSTRUCTION MANUAL

---

**LOAD MANAGER 1H**  
UNDER-VOLTAGE DETECTOR RELAY  
WITH HYSTERESIS



**MODEL #091-96-XX**

**A BATTERY VOLTAGE MONITOR WHICH  
DETECTS AN UNDER-VOLTAGE CONDITION.**

**3 YEAR WARRANTY**

---

170 Cherry Ave.  
West Sayville, NY 11796  
[www.kussmaul.com](http://www.kussmaul.com)

**KE KUSSMAUL™**  
**ELECTRONICS**  
*ENERGIZED AND READY, WHEN SECONDS COUNT*

Phone: 631-567-0314  
Fax: 631-567-5826  
[sales@kussmaul.com](mailto:sales@kussmaul.com)

## **INTRODUCTION:**

---

The 091-96-xx LOAD MANAGER 1H is a device, which continuously monitors the voltage of the battery. The unit is factory set to actuate at 12 volts, for 12 volt models or 24 volts for 24-volt models, but may be adjusted to other voltages. The output relay is capable of switching 30 amperes, and both a “normally open” and normally closed” contact are provided.

## **INSTALLATION:**

---

Connect the Load Manager 1H to the battery, the load and the fuse as illustrated in figure 1. This is a typical circuit. Other circuit configurations are possible. It is always necessary to connect the Bat+ and Bat- terminals to that point at which the voltage is to be sensed.

## **ADJUSTMENT:**

---

The factory setting for the Load Manager 1H is 12.0 volts (24 v). Field adjustment of the set point is possible. To do this, remove two screws holding down the cover. Note the position of the voltage adjustment trimmer R6. This is the 12-volt (24 v) setting. To decrease the voltage turn counter clockwise. To increase the voltage turn clockwise. Two indicator LED's are provided adjacent to the terminal strip. When the green LED is lit, the voltage sensed is normal. When the red LED is lit, the voltage is below the set point. The voltage detector can be tested by gradually lowering the system voltage while simultaneously measuring the voltage applied to the input terminals with a precise voltmeter and noting the voltage at which the red LED turns “ON”.

The 091-96-xx Load Manager 1H contains an adjustable high hysteresis feature. With the normal trip point set to 12.0 volts (24.00 volts), the hysteresis circuit maintains the relay energized until the voltage increases above 13.45 volts. This assures that the loads being controlled are not energized until the sensed voltage reaches 13.45 volts (26.9 volts). This limits the ON/OFF cycling of the load. The hysteresis may be adjusted using trimmer R15. Turning R15 CCW will decrease the hysteresis while turning CW will increase. Unless absolutely necessary it is recommended that the hysteresis remain at the factory setting.

Whiting has adjusted the Load Manager to trip at 10.5 volts  
In cold weather or extreme conditions the batteries could easily drop below 12 volts making the CommandLIFT inoperable with the Kussamal factory settings.  
It is not recommended that the voltage be adjusted any further.  
**DO NOT ATTEMPT TO ADJUST THE HYSTERESIS SETTING.**  
If the CommandLIFT doesn't operate and the red LED is illuminated on the Load Manager, start the vehicle.

## SPECIFICATIONS:

---

Model	091-96-12	091-96-24
Input voltage	10 to 15 volts D.C.	20 to 30 volts D.C.
Input amps, relay off	0.02 Amps	0.015 Amps
Input amps, relay on	0.1 Amps	0.05 Amps
Relay contacts, amps	30 Amps	30 Amps
Case	non-weatherproof	non-weatherproof
Weight	4 ounces	4 ounces

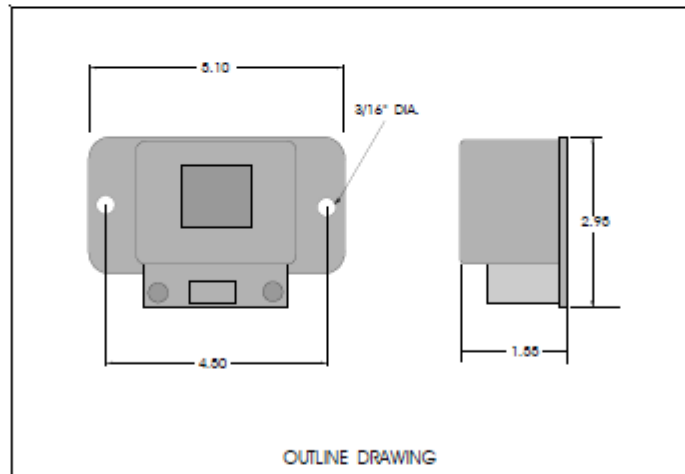

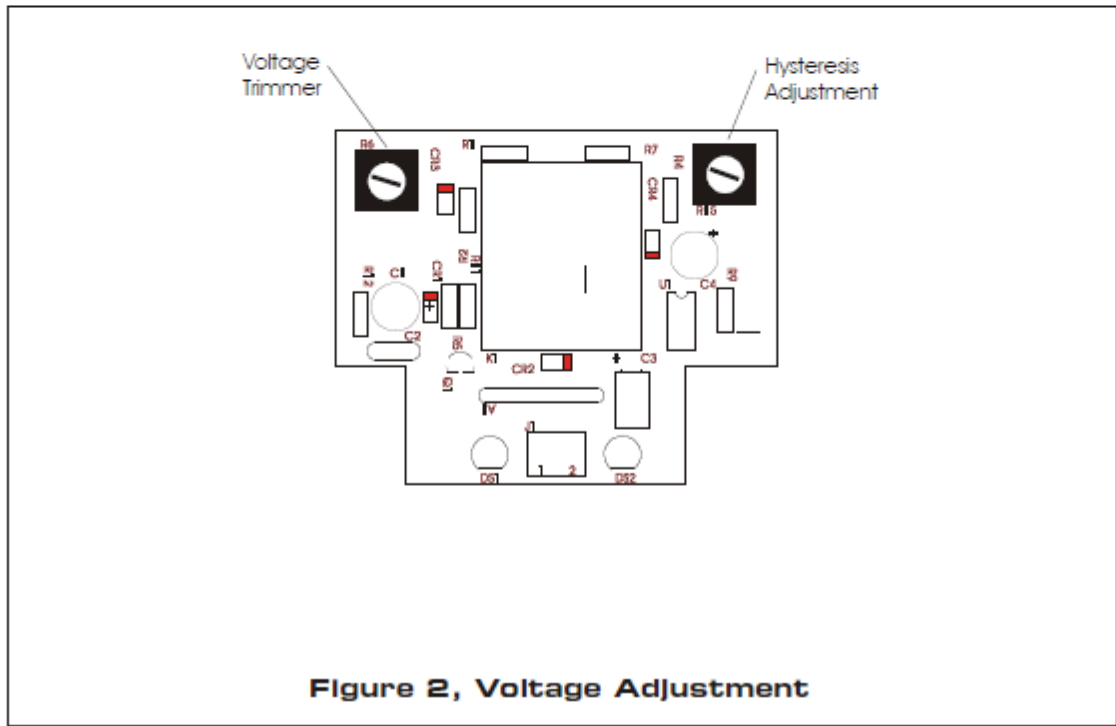
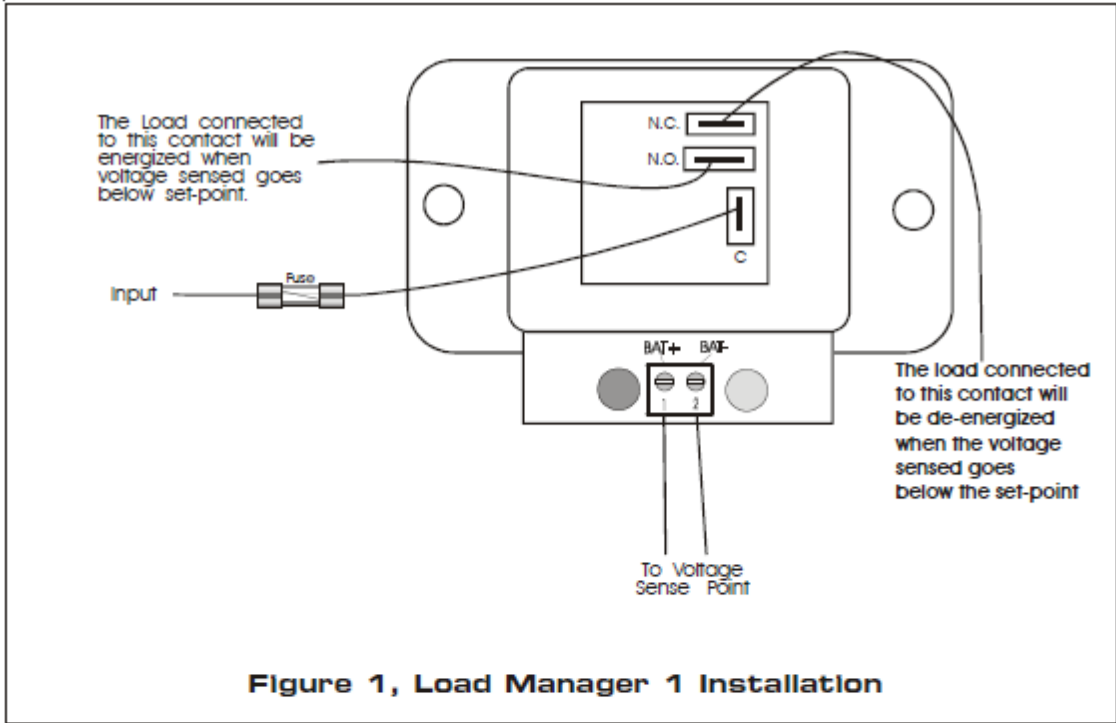

## Appendix E – Detailed remote control transmitter programming instructions for keypad / remotes

### How to program keypads and / or remotes

Below are the basic instructions to program any remotes and keypad. You will have to locate the RC35a relay in the CommandLIFT control box. The steps listed below will erase all wireless devices from the memory and require them to be re-programmed.

Programming the HD007-B keypad to the RC35a controller:

1. Remove the in line fuse leading to the CommandLIFT control box, thus removing power to the relay.
2. After 5 seconds replace the fuse and within 3 seconds press both buttons on one of the key fobs.
3. The RC35a relay should send a lock signal out indicating that it has entered code learning mode, at which time press any button on all fobs or wall mounted switches.
4. After the final fob / switch has been programmed press 5,5,5 on the keypad to program it.
5. As you successfully program each transmitter the relay will send out a lock signal indicating that device is programmed.
6. Please note that you will only have 5 seconds after the relay enters code learning mode to press the buttons on one of the fobs or keypad or it will time out and you will have to start over at step one. You have 5 seconds between each device.

### How to use the HD007-B Wireless Keypad

Close / Lock : Press 5,5,5. Green LED will flash to confirm. Door will close.

Open / Unlock : Press 1,3,5,7,9,\*. Green LED will flash to confirm. Door will open.

### How to modify your password

The factory default password is 1,3,5,7,9,\*. To change this default code to a custom code press \*,\*,\*, old code\*, new code,\*. If the new code is accepted the red LED will flash 2 times. 4 red flashes indicates the code was not accepted. The new code must be 4 – 8 digits and not include the \*.

### What to do if you forget your password

If you forgot your password please contact [support@poplocks.com](mailto:support@poplocks.com). Instructions and troubleshooting information is available at [www.poplocks.com](http://www.poplocks.com)

### How many times can you input a password?

After 3 incorrect attempts to enter your password the red LED will flash quickly for 5 seconds and you will be locked out for 2 minutes. During the 2 minutes the keypad will not accept any codes.

### How to replace the battery?

The battery compartment is in the rear housing. Depending on the type of door the keypad is installed on you may be able to access the compartment from inside the door. If there is no access the keypad will need to be removed from the face of the door. Remove the back cover and install a new 23A battery paying attention to the polarity.



## ***Trouble Shooting Check List***

Always ensure the mechanical components of the system are working as they should before moving on to any of the steps outlined below.

The system consists of the roll up door, counter balance, door track, CommandLIFT motor unit, CommandLIFT track.

Open the small cover on the CommandLIFT motor and disengage the motors. Operate the door all the way up and all the way down by hand. It should move without a lot of effort. If you find the door is difficult to lift or close, the system needs some maintenance. Disconnect the emergency release cable and turnbuckle between the door and motor unit. Test the door again, all the way up and all the way down. Perform any required maintenance to ensure the door works smoothly.

Move the CommandLIFT motors the full length of the CommandLIFT track. They should slide freely and not bind anywhere.

If the motor unit is difficult to move it needs to be removed and serviced.

Once the door and CommandLIFT motor unit are operating smoothly by hand, reconnect the door and motor unit, retest the door with the motor attached by hand.

Engage the motors by pushing the lever forward and test the system with the remote.

1. Is the battery in the key fob transmitter dead?  
Push either button on the transmitter, a red LED indicator light should come on at the top of the transmitter. If the red light does not come on replace the battery with an A23 battery available from Whiting or a local retailer.
2. Is the in line fuse or the fuse on the CommandLIFT circuit board blown?  
If so, replace fuse. If fuse blows again, check for poor connections or short circuits. Shorts can be caused from exposed wires touching other wires or the vehicle body.
3. Is the motor engaged?  
Try to move the door by hand. If it moves at all by hand the motors are not locked into the drive position. Open the small cover on the motor unit and ensure the lever is pushed as far forward as possible. The lever will make a distinctive clicking sound when it engages.
4. Is there power to the CL electronic enclosure?  
Check voltage at battery and at stud terminals in the CommandLIFT box. Voltage should be checked while the CommandLIFT is idle and under load. If the voltage drops below 10.5 volts in either situation the Load Manager will disconnect power

to the CommandLIFT circuits and the red LED light will come on.  
To rectify the problem, ensure all connections are clean and secure. Make sure there is no corrosion on the wires. Ensure the battery is in good condition and is adequately sized. Start the vehicle.

5. When you push either button on the key fob remote, can you hear a clicking sound from the RC35a receiver in the control box?

If it doesn't make any sound, try again with spare key fob remote.

If the receiver does click, does LED number D15 for close or D16 for open on the circuit board illuminate momentarily?

If the LED on the circuit board lights when remote is pushed the key fob and receiver are working properly.

6. Check the voltage on the circuit board at position number P1 and P2, it should read approximately 32 volts.

If there is no voltage, the step up converter may be faulty.

Call Whiting.

7. Check the voltage terminals M1 and M2 when the remote is pushed. It should go from zero in standby to 32 when the remote is pushed.

If it doesn't go to 32 volts the circuit board could be faulty.

Call Whiting.

8. Check voltage at motor connections in motor housing. Remove from cover of motor housing to expose motor and light connections. Unplug the motors and check for power when the remote is pushed. If there is no power the line between the electronic control box and the CommandLIFT may be compromised or have a poor connection. Check continuity through the CommandLIFT cable and repair or replace as necessary.

If there is power but the motors won't run, the motors could be faulty.

Call Whiting.

The CommandLIFT is working but isn't acting as it should.



**1. The CommandLIFT closes against the sill and then goes back up a few inches.**

Check for obstructions on the floor. Small pieces of debris or ice buildup.

The sensor is either in the wrong position or not reading the magnet in the cable slider housing or there is a fault in the sensor wire.

With the door fully closed LED #D13 should be illuminated. If not follow the following steps.

Remove the sensor cover strip on the road side of the CommandLIFT rail. With the door closed compare the location of the coil cable slider with the sensor. The sensor should be clamped into the rail just above the cable slider. If the sensor is behind the slider the CommandLIFT logic is sensing the floor as an obstruction and making the door go back up.

Adjust the sensor so until the LED D13 comes on, clamp it into position with the Allen screw and retest the unit.

If the sensor is in the correct position but the light won't come on, the sensor could be faulty.

The sensor is a N/O Reed switch. These switches sometimes stick. Gently tap the sensor with the end of a screwdriver, if the light comes on the switch needs to be replaced ASAP.

Unplug the sensor from the cable and reconnect it. Try the CommandLIFT again, if it still doesn't work, call Whiting.

**2. The CommandLIFT goes past the open position and jams against the safety stop screw at the end of the rail.**

The sensor is either in the wrong position or not reading the magnet in the cable slider housing or there is a fault in the sensor wire.

With the door fully open LED #D14 should be illuminated. If not follow the following steps.

Remove the sensor cover strip on the road side of the CommandLIFT rail. With the door open compare the location of the coil cable slider with the sensor. The sensor should be clamped into the rail just above the cable slider.

Ensure the sensor is plugged in and in the correct position on the track to stop the door at the desired location. If the sensor is too far forward in the vehicle the motors or door could become jammed.

If the door is driving past the sensor without stopping check to see if the red LED # D14 flashes on the board as the slider goes past the sensor.

If the LED doesn't flash the sensor could be faulty, the connector from the cable to the sensor could be dirty or the cable from the electronics enclosure to the motor unit could be compromised.

Unplug the sensor from the cable and reconnect it. Try the CommandLIFT again, if it still doesn't work, call Whiting.

**3. The CommandLIFT works but stops half way through the cycle.**

This fault can be intermittent. If it happens in very cold weather it is usually a case of frozen panel joints, stiff side seals, and frozen roller bearings. Use low temperature

lubricants to remedy these cold weather issues. Wiping the side seals with lubricant can also help reduce friction on the door face during extreme cold conditions.

The CommandLIFT has a safety reverse feature based on amperage. When the amps during a cycle reach a certain threshold the program believes there is an obstruction and will stop and reverse if the motors were on the down cycle, or it will simple stop abruptly if the motors were on the up cycle.

This could be from an under or over balanced door, a door that doesn't fit into the opening properly, angle and length of turn buckle connector rod may need to be adjusted.

Occasionally a hard reboot will also rectify this problem.

To reboot the system, either disconnect the positive lead from the battery for 5 seconds or pull the in line fuse for 5 seconds. Do not use the fuse on the CommandLIFT circuit board to reboot.

If rebooting doesn't work, follow the maintenance procedures outlined at the beginning of this guide.

If all systems are working easily by hand and have been rebooted and the opener still won't work, call Whiting.

#### **4. The door won't close tight against the floor.**

Check the angle and length of the turn buckle connector rod. It should be at approximately 45 degrees in the closed position. If the rod is too short the motor will hit the stop screw before the door hits the floor.

#### **5. The CommandLIFT motors are noisy.**

Check to ensure the nylon sliders on the motor housing are still in place and in good condition.

Although lubrication of the motors isn't necessary it is sometimes necessary to lightly lubricate the aluminum pathway that the motor slides in. Use a rag wetted with silicone lubricant and wipe the entire length of the channel on both sides of the motor pathway.

Use the same rag to wipe inside the coil cable pathway.

Never use grease and wipe away all excess lubricant.